

**IC3000D Series**  
**(2CH Digital Indicators with Alarm)**



◀ contents ▶

⚠ WARNING / CAUTION / NOTE	2, 3
1. Checking the Accessories	4
2. Part Name	4
3. Installation	4
4. Terminal Diagram	5
6. General Specification	6
7. Major Function	7
8. Operation & Setting	8
9. Ordering Code	10

※ Be sure to observe following warning / cautions and those provided in the text. In order to secure safety in handling the instrument.

### ⚠ WARNING

- |                         |  |
|-------------------------|--|
| General                 | ▶ In order to prevent electric shock, be sure to disconnected this instrument from the main power source when wiring.  |
| Protective Grounding    | ▶ In order to prevent electric shock ; be sure to provided protective grounding prior to turning on this instrument.<br>Do not cut a protective grounding conductor disconnected protective grounding. |
| Power Source            | ▶ Make sure that the supply voltage for this instrument conforms to the voltage source.<br>▶ Attach protective cover prior to turning on this instrument.  |
| Fuse                    | ▶ In order to prevent a fire, use only our specified fuse.<br>▶ Don't short-circuit a fuse.  |
| Working Environment     | ▶ Do not operate this instrument in the environment where it is exposed to a combustible, explosive, corrosive gas or water, steam.  |
| Input and Output wiring | ▶ Provide input and output wiring after turning off the power.   |

### ⚠ CAUTION

- |                         |  |
|-------------------------|--|
| Inside of instrument    | ▶ Do not disassemble the inside of the instrument.<br>▶ Prevent inflow of dust, water, oil and wiring dregs in to the instrument.  |
| Input and Output wiring | ▶ Do not use empty terminals for other purposes such as relaying, etc.<br>▶ Wire correctly after checking the polarity and purpose of the terminal.<br>▶ When wiring the instrument, separate from high voltage cables, power lines, and motor lines to prevent inductive noise. |
| Transportation          | ▶ When transporting this instrument or the equipment with this instrument incorporated in it, take measures to prevent opening the door and falling out the inner module.  |

### ⚠ NOTE

- |                                     |  |
|-------------------------------------|--|
| Instruction manual                  | ▶ Deliver this instruction manual to an end user.<br>▶ prior to handing the instrument be sure to read this manual.<br>▶ If you have any question on this manual or fine any errors omissions in this manual, contact our sales representative<br>▶ After reading this manual, keep it carefully by the instrument.<br>▶ When the manual, is lost or stained, contact our sales representative.<br>▶ It is prohibited to copy or reproduce this manual without our permission. |
| Checking the accessories            | ▶ Upon delivery instrument, unpack and check its accessories and appearance. if there are missing accessories or damage on the appearance contact our dealer where you purchased the instrument or our sales representative.   |
| Installation                        | ▶ When installing this instrument, put on a protective gear such as safety shoes, helmet, etc. for your safety.  |
| Maintenance                         | ▶ Only our serviceman or persons authorized by NEWINS are allowed to remove and take the inner module, the main unit and printed circuit boards apart.   |
| Disposal                            | ▶ Disposed the used products in a correct way.<br>▶ Do not incinerate plastics of maintenance parts and replacement parts. A harmful gas mat be produced.<br>▶ To disposed of this instrument, consign to the special agent as an industrial waste.  |
| Cleaning                            | ▶ Use dry cloth to clean the surface of this instrument<br>▶ Do not use any organic solvent.<br>▶ Cleaning the instrument after turning off the power.   |
| Revisions                           | ▶ This instruction manual is subject to change without prior notice.   |
| Evasion of responsibility guarantee | ▶ Be sure to observe the caution in operating, maintaining, and repairing this instrument. We will not be responsible for or guarantee the damage resulting from negligence of them.   |

## 1. Checking the Accessories

when you received, please check the Insufficient accessories and defective products shape.  
If the lack of parts, please contact the company.

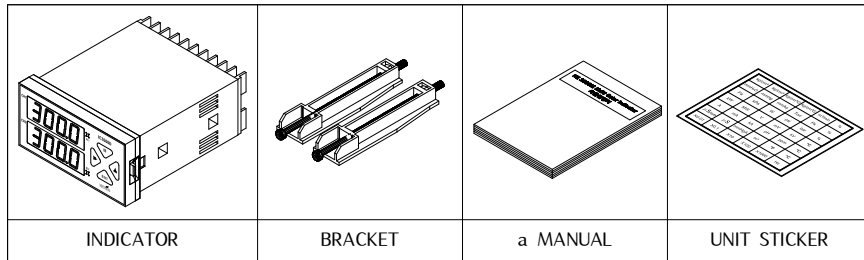

## 2. Parts Name

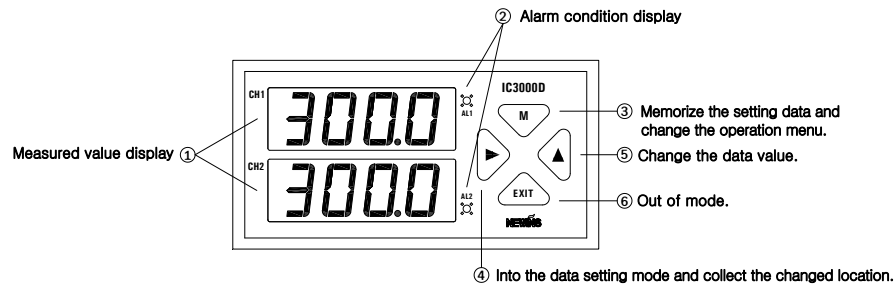

## 3. Installation

### 1. mounting

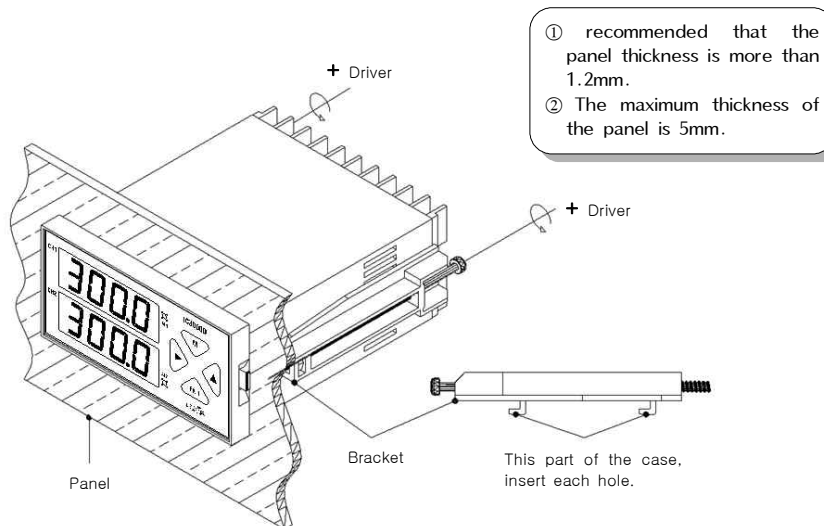

## 2. Outside dimension & Panel cutting size

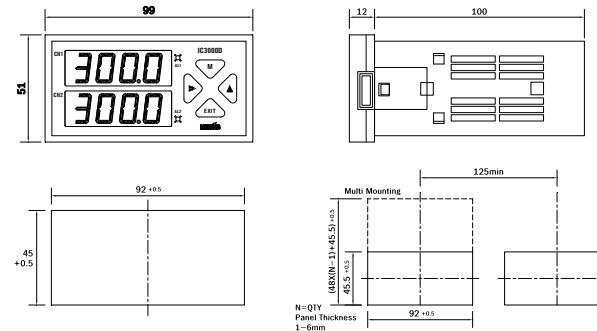

⚠ **Caution** : Maintenance and to ensure the safety of the device if you add a space to more than 125min size is recommended.

## 4. Terminal diagram

### 1. Terminal wiring

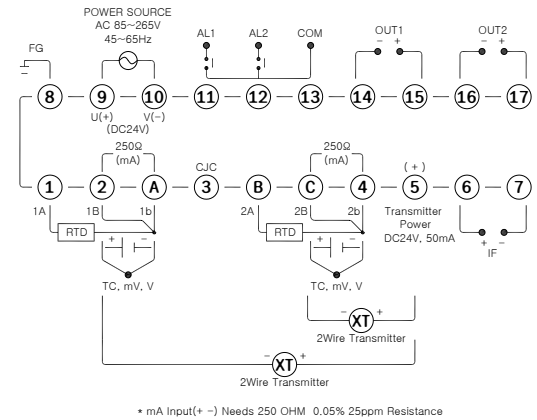

### 2. A power source wiring

#### ⚠ **Caution**

1. For an electric shock prevention to turn on electricity to the machinery and tools which after one sees a protective ground connection surely.
2. To the electric wire terminal to use the insulation sleeve compression terminal.
3. The device's power supply voltage to match the voltage of the power is in check.
4. For the protection of life to turn on an electric current to the instrument after attaching the cover.

#### ⚠ **Attention**

1. To all the member front line 600V vinyl insulation front lines (JIS C3307), or to use the front line of above considerable width.
2. To the protective ground terminal to connect above of 3rd type(to connect below earth resistance 100Ω and smallest size 1.6mm).
3. Other protection devices and grounding, the grounding in public may be affected by noise. Accordingly the public are advised not to other devices.

## 5. Features

- ▶ Multi-range 2Channel input (T/C, RTD, Volt, mA, etc)
- ▶ Two 4Digit FNDs are installed and displayed for each channel
- ▶ High accuracy 16bit A/D converter
- ▶ Peak hold function (Highest & Lowest)
- ▶ 4 points alarm & Dead band set
- ▶ Free voltage (AC 85~265V, 45~65Hz)

## 6. Specification

### ▶ Input Type

Sensor Type	Range	Scale	Symbol	
TC	B(PR)	0~1800℃	-	ℓℓ-b
	R(PR)	0~1750℃	-	ℓℓ-r
	S(PR)	0~1750℃	-	ℓℓ-S
	K(CA)	-200~1350℃	-	ℓℓ-ℓ
	E(CRC)	-199.9~700.0℃	-	ℓℓ-E
	J(IC)	-199.9~800.0℃	-	ℓℓ-J
T(CC)	-199.9~400.0℃	-	ℓℓ-ℓ	
Volt	mV	-50.0~50.0mV	-1999~9999	̄m̄v
	Volt	-1.000~1.000V	-1999~9999	̄v̄
	Volt	-10.0~10.0V	-1999~9999	̄V̄
mA	mA	4.00~20.00mA	-1999~9999	̄m̄A
PT	PT100Ω	-199.9~800.0℃	-	ℓ-Pl
	PT100Ω	-199.9~500.0℃	-	J-Pl

### \* It need the external 250/±0.1% 25ppm resistance to use mA input type

- ▶ Measuring and display cycle : 200ms(mV, Volt, mA type), 400ms(TC, RTD type)
- ▶ Input resistance : Volt-400kΩ, Others type-1kΩ
- ▶ Signal source resistance : Pt 100Ω type-30Ω/line, Others type-300Ω/line
- ▶ CMRR(Common Mode Rejection Ratio) : 140dB or more
- ▶ NMRR(Normal Mode Rejection Ratio) : 60dB or more
- ▶ Moving average filter
- ▶ Built-in Sensor power source : DC 24V 30mA ±0.5%
- ▶ Accuracy : Display ±0.2% FS
- ▶ Isolation current output(Optional)  
Current : DC 4.00~20.00mA  
Maximum load resistance : 600Ω  
Isolation resistance(Input-Output) : 100MΩ or more(DC 500V)
- ▶ Alarm(Optional)  
Contact output type : Normal open  
Max switching power : 60W 125VA  
Max switching voltage : DC 220V, AC 250V  
Max switching current : DC 2A, AC  
Max Carrying current : DC 3A, AC
- ▶ Ambient temperature & Humidity  
Operation : -10~50℃, 10~90%  
Storage : -20~70℃, 5~95%
- ▶ Power supply  
Voltage : AC 85~265V(45~65Hz) DC 24V(Optional)  
Power consumption : Max 4VA  
Isolation resistance : 100MΩ, DC 500V (FG-Input, FG-Power, Power-Input, Input-Output)
- ▶ Communication interface(Optional)  
Type : RS-485 & MODBUS RTU  
Speed : 4800, 9600, 19200bps  
ID(address) setting : 0~99
- ▶ Etc  
Weight : 250g  
Mounting : Panel mount , Dimension : 99(W) X 51(H) X 112(D)mm

## 7. Major Functions

### ▶ Display scaling function (H1rn, L1rn, H2rn, L2rn)

This Function changes and sets the display value according to scale and input range.

Ex) In case of input range 4.00~20.00mA and Level 0.00~7.00m

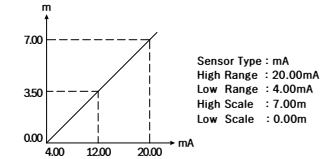

### ▶ Output scaling function(H15C, L15C, H25C, L25C)

\* Only possible when the sensor is mV, Volt, mA  
This function can change the 4.00~20.00mA value as the output scale.

Ex) In case of display value 0.00~7.00m, Output 4.00~20.00mA

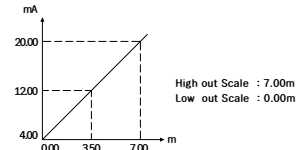

### ▶ Sensor compensation function (S1Ad, S2Ad)

The function is useful for compensating error by long sensor line or changed zero point by aged sensor.

Ex) Before sensor adjust = 510℃

After sensor adjust = measured value + compensated value  
= 510 - 10  
= 500℃

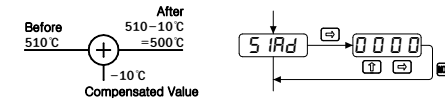

### ▶ Function (F-51, F-52)

\* Only possible when the sensor is mV, Volt, mA

**L in** : Pass the input as it is.

Used for general input type and linearity input.

**root** : Pass the input after  $\sqrt{\quad}$ .

Used for flow rate by orifice.

**L ml** : Like level measuring, when it does not display measuring under limit value,

It always can display zero by using limit value function.

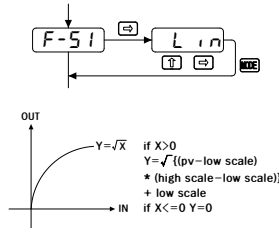

### ▶ Alarm function (RL1n, RL2n)

The alarm consists of 4 relays, and it can output relay contact output individually.

RL1n: C1-H, C1-L, C2-H, C2-L

RL2n: C1-H, C1-L, C2-H, C2-L

Ex) AL-1: High alarm value 500.0, AL-2: Low alarm value 100.0, Alarm dead band setting 0.5

The high alarm(AL-1) is ON when the present value(PV) is 500.0 or more, and OFF when

499.5 or less. The low alarm(AL-2) is OFF when the present value(PV) is 100.5 or more, and ON when 100.0 or less.

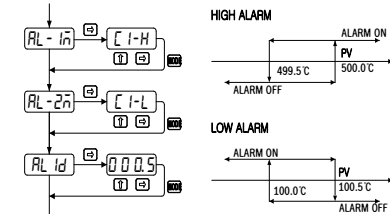

► Filter

This function is moving average filter and has 5 kinds  
It displays sample value on an average the in recent input value 4,8,16,32,64  
In case of setting the filter function, the response will be delay.  
When the output and display value are changed by irregular input, it is possible to get regular input and display value by using filter function.

## 8. Operation & Setting

### ⚠ CAUTION Initialization of the data (All Reset)

It is All reset when ship the goods from factory. If you want initialize all parameter, please reset the instrument. Push the **MODE** key and **EXIT** key at the same time and ON the power. It is initialized and operation by new setting value.

► Initial setting value is,

Sensor type(TC-K), Alarm1(1350), Alarm2(1350), Dead band(1), Peak mode(0)  
Sensor correction(0),Function(LIN), High output scale (1350), Low output scale(-200), Alarm type1(H), Alarm type2(H), Alarm type3(H), Alarm type4(H), Filter(8), Unit(0)

### 1. Operation Mode

- Usually user may setting the Alarm value and confirming the Peak value during operation.
- The peak value must not erased at least 10years because it stored in the semipermanent EEP-ROM.
- The Alarm mode (High, Low) is operated setting value which set in the setting mode.

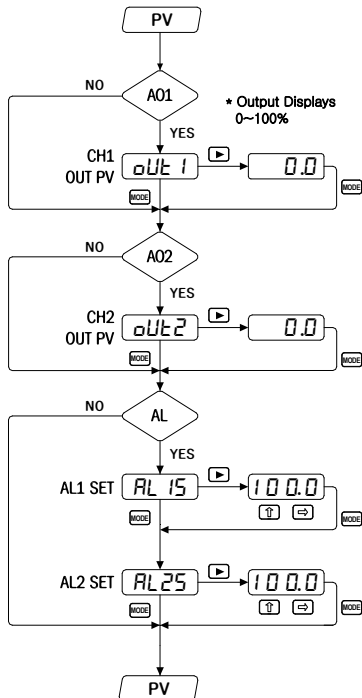

- Make flickering the wanted place by **⇐⇒** key and setting the value for data setting.
- Push the **↑**, the figure repeat to 0,1,2... 9,0 and the best position repeat to 0,1,2...9,-,-,1,0 . If you want to output the mode,
- push the **EXIT** then will go out into the PV value Mode.

### 2. Setting Mode

- Change the setting **⇐⇒** **↑** push at the same time to move setting mode.
- Move to display mode in every mode push the **EXIT**
- Data setting method
  - ① Setting the decimal point by **↑**
  - ② Flickering the purpose digit by **⇐⇒**
  - ③ Selecting the data by **↑**
  - ④ Setting data by pushing the "mode"
  - ⑤ Decimal point can set only the input range high or input scale high mode.

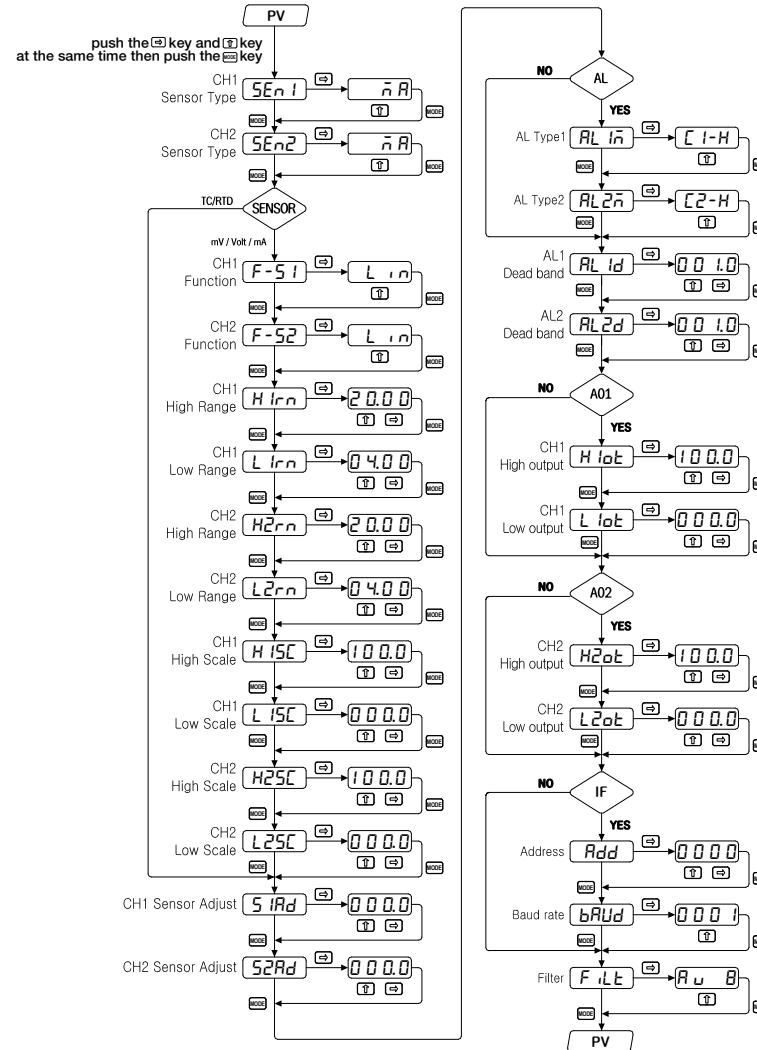

## 9. Ordering Code

IC 3				D		Description
Type	1					Indicator
	2					Indicator with 1 Alarm
Analog output	0					None
	1					DC 4.00~20.00mA
	2					DC 4.00~20.00mA (2output)
	3					Etc.
Power		0				AC 85 ~ 265V (45 ~ 65Hz)
		1				DC 24V
		2				Etc
Interface				0		None
				1		Modbus RTU(485)

## NEWINS Co., Ltd.

Seoul Office :  
Sales  
Department

506, Business Building, Magok M Valley 9,  
103, Gonghang-daero, Gangseo-gu, Seoul, KOREA  
Tel : +82-2-2668-2233, Fax : +82-2-2668-5100

Head Office :  
Factory

301-1101 ~ 3, Ssangyong 3th, Buchen Techno-Park,  
397, Seokcheon-ro, Ojeong-gu,  
Buchen-city, Gyeonggi-do, KOREA  
Tel : +82-32-624-0770, Fax : +82-32-624-0772  
<http://www.newins.co.kr> E-mail : [sales@newins.co.kr](mailto:sales@newins.co.kr)